



Ergotron® TM

Large Display Tilting Wall Mount

Highlights

- Constant Force (CF) patented motion technology produces smooth tilt adjustment—set display in position with just a light touch



- Single-SKU design fits most screens greater than 32" up to 175 lbs (79 kg)
- Simple 3-step installation
- Easily connect and detach display
- Integrated security fasteners deter removal
- Includes fasteners for mounting to wood studs or concrete wall surfaces

- UL certified and listed to UL Standard 1678. This product has been tested to hold four times its maximum load capacity per UL standard (do NOT exceed listed weight capacity in actual use)



- 5 year warranty

Enhance any viewing experience. Ergotron's Large Display Tilting Wall Mount is the perfect accessory for large plasma displays or LCD TVs up to 175 lbs. Attaching your valuable (and heavy) flat panel investment to a wall can be nerve-racking. So we took our engineering know-how and created an extremely stable wall mount solution. Then we made it better. We've added our patented CF motion technology.

Now anyone at the office or at home (even children) can effortlessly adjust the tilt of a screen. And once assembled, Ergotron's unique security fasteners deter others from removing your display.

- Tilt your screen with just a light touch; no knobs or levers
- Sleek, silver and charcoal grey design complements home or office decor
- Protect your investment: integrated security fasteners hold the large display or TV in place
- View in comfort: cut glare and improve sight lines for optimal viewing
- Buy smart: approximately half the price of competing models!
- Single-SKU design fits most flat panel screens greater than 32"



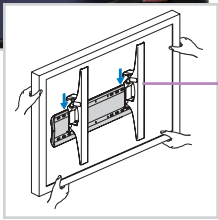

Easily connect and detach display

Simple Installation

3-step process ...

- ① Attach wall plate to chosen location on wall
- ② Attach mounting brackets to display
- ③ Hang display on wall plate



Range of Motion

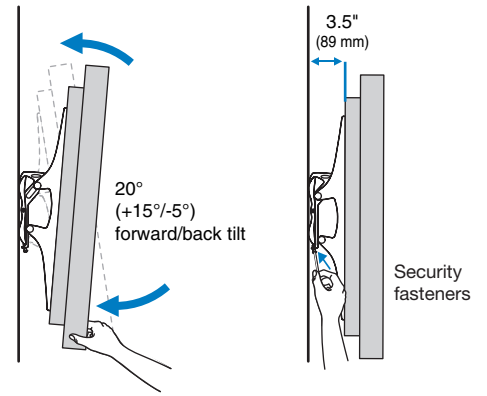

No knobs or levers are used to activate the tilt motion or hold the position of display!

Constant Force (CF) patented motion technology produces smooth tilt adjustment



Security fasteners on mounting brackets prevent easy removal of the display

Wall plate attaches to vertical wall surfaces. Includes hardware for mounting to wood studs (16" centered studs) or concrete walls

Profile off the wall 3.5" (89 mm)

60-603-003 LCD Size	LCD Weight	Lift	Tilt	Pan	Rotation	VESA
32-65"	≤ 175 lbs ≤ 79 kg	—	20°	—	—	MIS-D/E/F*

60-601-003 LCD Size	LCD Weight	Lift	Tilt	Pan	Rotation	VESA
42-65"	≤ 175 lbs ≤ 79 kg	—	20°	—	—	MIS-D/E/F*

Product Name	TM Tilting Wall Mount	TM Tilting Wall Mount, XL
Part Number	60-603-003 (silver)	60-601-003 (silver)
Product Includes	Wall/display brackets and hardware fastener kit	Wall/display brackets and hardware fastener kit
Shipping Dimensions	34.6"W x 12.9"H x 4.3"D (88.0 x 32.7 x 10.8 cm)	39.5"W x 12.9"H x 4.3"D (100.3 x 32.7 x 10.8 cm)
Shipping Weight	14 lbs (6.3 kg)	16 lbs (7.3 kg)
Warranty	5 years	5 years
*Compatible Display(s)	≥ 32" displays, mounting holes must fit spacing range: Horizontal = 100 mm (min.) to 600 mm (max.) Vertical = 100 mm (min.) to 450 mm (max.)	≥ 42" displays, mounting holes must fit spacing range: Horizontal = 100 mm (min.) to 800 mm (max.) Vertical = 100 mm (min.) to 450 mm (max.)
<i>Do not use with very thin or lightweight displays—for these displays Neo-Flex Tilting Wall Mounts are recommended</i>		

© 2013 Ergotron, Inc. rev. 03/14/2013 Literature made in US Content is subject to change without notification

Americas Sales and Corporate Headquarters

St. Paul, MN USA
(800) 888-8458
+1-651-681-7600
www.ergotron.com
sales@ergotron.com

EMEA Sales

Amersfoort, The Netherlands
+31 33 45 45 600
www.ergotron.com
info.eu@ergotron.com

APAC Sales

Tokyo, Japan
www.ergotron.com
apaccustomerservice@ergotron.com

Worldwide OEM Sales

www.ergotron.com
info.oem@ergotron.com

